

6W ABS Projection Loudspeaker

- Weatherproof Sound Projector
- Suitable for Speech & Music
- Can be supplied to meet the Requirements of BS5839:8
- Easy to Install using Stainless Steel Bracket



Projection speaker surface mounted c/w bracket ideal for applications where a high quality reproduction of voice and music is required.

This unit is splash-proof therefore suitable for a wide variety of indoor and outdoor applications.

Ideal Applications

- Small Pool Area
- Cinemas
- Shopping Malls
- Leisure Complexes

Dimensions (mm)

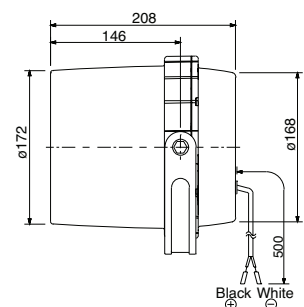
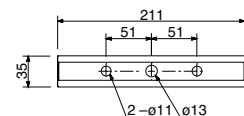
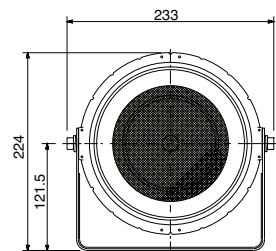

Technical Specification

Frequency Response

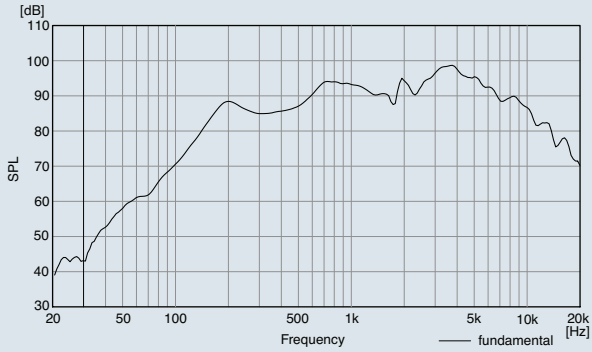

Technical Specification:

Power Handling	6 watts
Frequency Response	150 Hz - 15kHz
Line Tap (W)	6, 3, 1.5, 0.8 watts
Dimensions (diameter x depth)	180mm x 200mm
Colour	White
dB 1W 1 Mtr	95dB
Weight (inc. packaging)	1.4 kg
Ceiling Cut Out	N/A
Stock Code	200-210-05

Polar Pattern

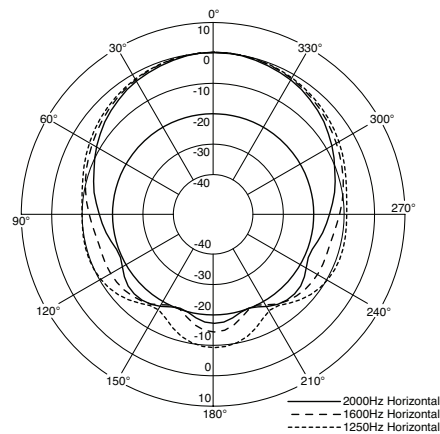
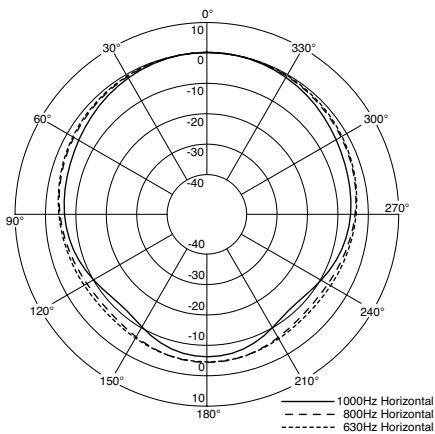

Company Policy is one of continuous improvement, we reserve the right to change specification without prior notice

Protec Fire Detection Plc, Protec House, Churchill Way, Nelson, Lancashire, BB9 6RT

Tel: 01282 717171 Fax: 01282 717273 Web: www.protec.co.uk Email: sales@protec.co.uk