

## Music Cabinet Loudspeaker

- Available in Black & White
- Quality Sound Reproduction
- 2 Way Enclosure
- Complete with Universal Mounting
- Variable Tapping Selection
- Integrated Volume Selector



This durable 20 Watt Music Cabinet Loudspeaker incorporates a 2-way enclosure, a custom loaded 5" polypropylene coned low frequency drive unit and a neodymium high frequency tweeter matched with a passive crossover.

Designed for use in shops, clubs, themed environments, wine bars etc. This unit provides high quality sound reproduction from a compact and attractive injection moulded enclosure.

Available in black or white, 100 Volt line or 16 ohm versions, this unit is supplied complete with a universal mounting bracket which has a unique locking facility allowing mounting on the wall or ceiling with ease.

The JD20/T, 100 Volt Line version, has a variable tapping selection switch accessible from the front of the cabinet and can be adapted to comply with British and European Standards for voice alarm systems.

### Dimensions (mm)

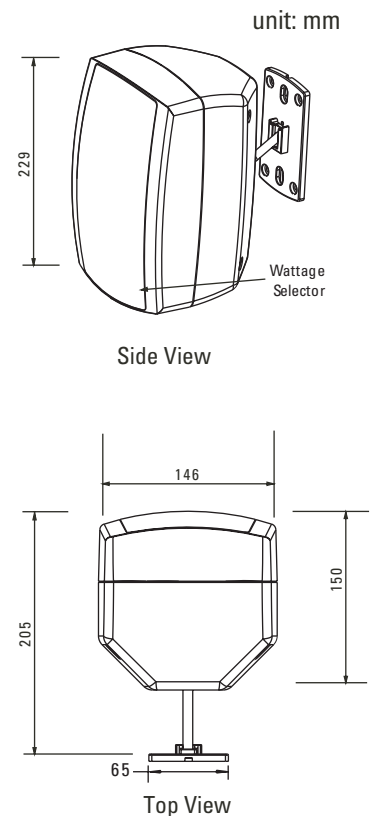

# Technical Specification

## Polar Pattern

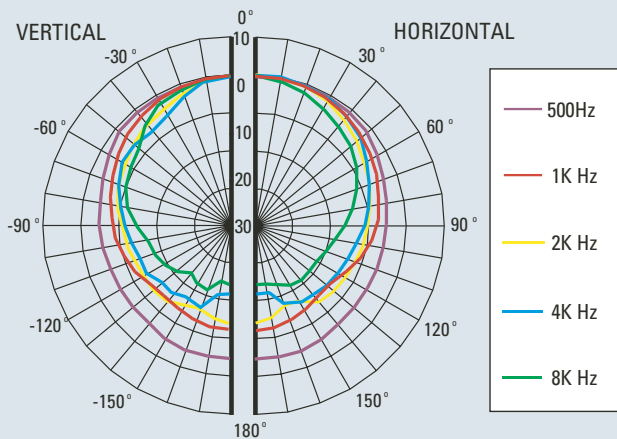

## Technical Specification:

Power Handling	20 watts
Rated Input	100 volt
Transformer Tappings	20, 10, 5, 2.5, 1.25 watts
SPL (1w/1m)	81dB
Max SPL (rated/1m)	97dB
Frequency Response	63Hz – 20kHz
Dimensions (W x H x D)	146 x 229 x 150mm
Material	ABS Moulded Housing
Weight (inc. packaging)	1.5kg
Colour	Black or White
Stock Code	200-032-15

## Frequency Response

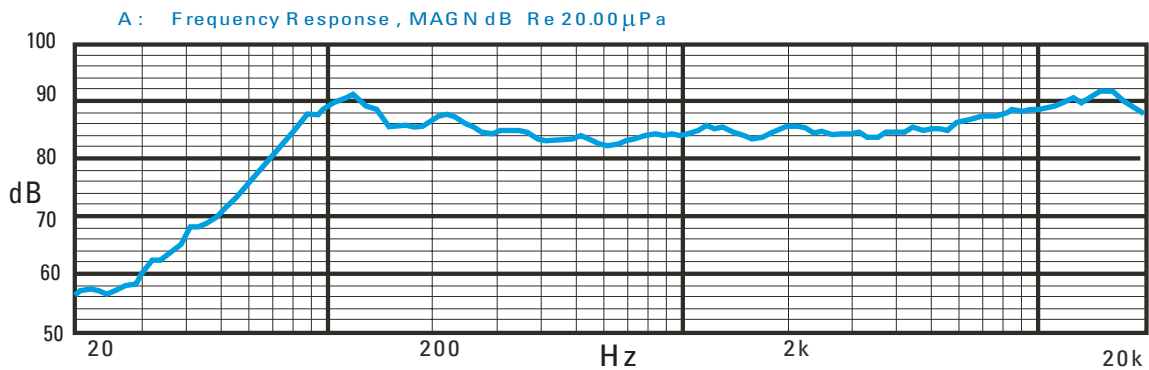

Company Policy is one of continuous improvement, we reserve the right to change specification without prior notice

**Protec Fire Detection Plc, Protec House, Churchill Way, Nelson, Lancashire, BB9 6RT**