

## 3000/MCP/WP Weatherproof Manual Call Point

- Unique Installation Concept
- Anti-Tamper Facility
- Enhanced Aesthetics
- Fully Approved to the Latest Standards
- Re-settable Break Glass Element
- Backward Compatibility



### 3000/MCP/WP

#### Weather Proof Manual Call Point -

Installation efficiency, flexibility and full compliance with the latest standards are at the heart of the the 3000/MCP/WP outdoor call point.

The 3000/MCP/WP is an IP67 sealed manual call point product. The enhanced environmental protection allows the unit to be installed in many external environments where water and dirt are likely to be present, making it a true waterproof and outdoor product.

The 3000/MCP/WP utilises a special terminal block, where all initial installation cabling is terminated. This terminal block is then simply connected to the back of the MCP. Simple, but effective with no re-termination required and no time wasted. In addition, the 3000/MCP/WP is supplied with three standard 20mm knock outs for cable entries, accommodating all types of surface wiring installations.

This MCP also helps preserve the integrity of the overall system as illegal removal of the product lid will result in the call point

operating and the system going into alarm. Full compliance with the latest standards is essential and the 3000/MCP/WP outdoor call point is fully approved to the latest EN54 Part 11 standard.

The 3000/MCP/WP is supplied with both a resistor and normally open, clean contact electrical options. These options are simply utilised by attaching the terminal block to the required connection in the back of the MCP. A variety of resistor values are available by request, with 180Ω offered as standard.

# 3000/MCP/WP Technical Specification

### Dimensions (mm)

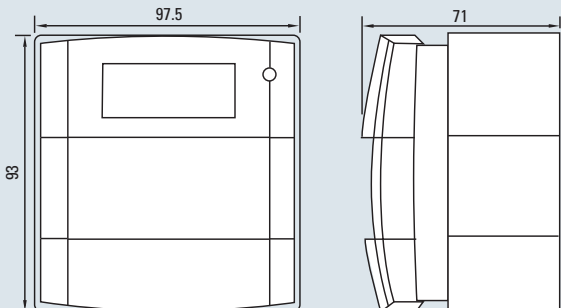

### Technical Specification:

Environment	-25°C to +75°C
Humidity	0-95% non condensing
IP Rating	IP67
Weight	296g
Operating Voltage	16 - 30V DC
Alarm Resistor	180Ω

### Typical Wiring

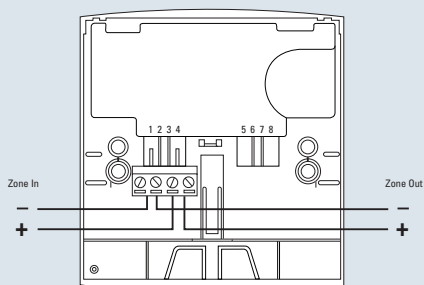

Company Policy is one of continuous improvement, we reserve the right to change specification without prior notice  
**Protec Fire Detection Plc, Protec House, Churchill Way, Nelson, Lancashire, BB9 6RT**