

- Ideal for Detecting Smouldering Fire
- Discreet Anti-Tamper Security Screw
- Latching 'Fire' LED
- Interchangeable with other 3000 Heads
- Range of Base Options
- Maximum Sensitivity to Smoke Detection
- High Resistance to False Alarm
- LPCB Approved to EN54 Part 7 : 2000



The Protec 3000 series of fire detectors, form a range of elegantly designed, aesthetic, low profile detectors which blend unobtrusively into modern working environments. All detectors incorporate a discreet anti tamper security screw and latching 'FIRE' LED indicator with the facility to activate a remote indicator unit. All detectors are interchangeable with a variety of base options which include relay bases, high efficiency sounder bases and sounder beacon bases.

3000/OP - Optical Smoke Detector

The low profile conventional optical smoke detector provides efficient reliable detection utilising the light scatter sensing principle with rapid response to a fire signal.

The detector incorporates a dual alarm verification function, which is designed to give maximum sensitivity to smoke detection, with high resistance to false alarms due to high air velocity, insects, dust and R.F. interference.

Providing early warning of a fire condition particularly for slow burning fires, the 3000/OP is an ideal general purpose smoke detector for offices, shops, corridors, factories, warehouses & computer rooms.

Approved to EN54 Part 7 : 2000 by
Loss Prevention Certification Board
Ref No. 201f/04

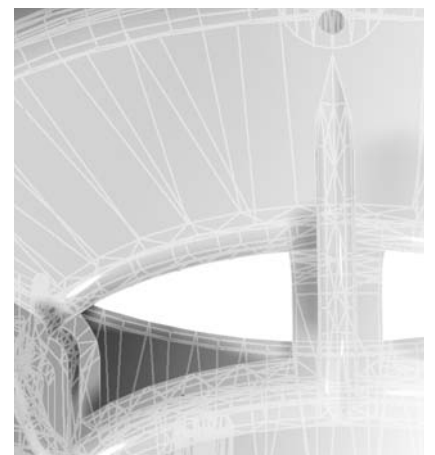

3000/OP Technical Specification

Dimensions

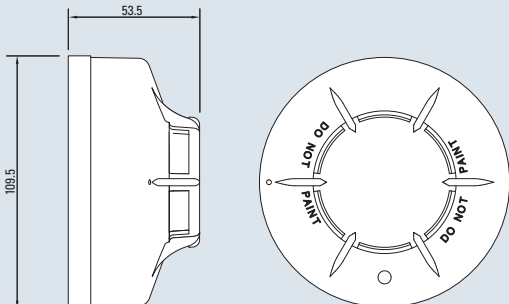

Typical Wiring using 3000/BASE

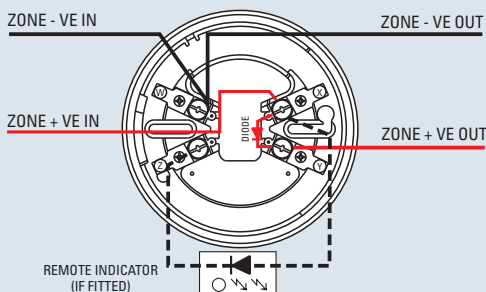

Technical Specification:

Environment	-10°C to 55°C
Ingress Protection	IP41
Applicable Standard	EN54 Part 7 : 2000
Approvals	Approved by L.P.C.B. Cert No 201f/04
Weight (excluding base)	119g
Operating Voltage	16V - 30V DC
Quiescent Current	50µA
Alarm Current	Determined by control panel - 50mA Max

BASE Options:

3000/BASE

Low profile common mounting base

3000/SB

24V DC Electronic sounder base

3000/SBEA

24V DC Electronic sounder beacon base

3000/RBNO or 3000/RBNC

Normally open or normally closed relay base



Company Policy is one of continuous improvement, we reserve the right to change specification without prior notice

Protec Fire Detection Plc, Protec House, Churchill Way, Nelson, Lancashire, BB9 6RT

Tel: 01282 717171 Fax: 01282 717273 Web: www.protec.co.uk Email: sales@protec.co.uk