



## Protec Algo-Tec™ 6300 Interactive Digital Addressable Fire Control System

# Protec

Protec Fire Detection plc

Protec Algo-Tec™ 6300

INTERACTIVE DIGITAL ADDRESSABLE

FIRE CONTROL SYSTEM

The Protec Algo-Tec™ 6300 Interactive Digital Addressable System unwrapped:

The Protec Algo-Tec™ 6000 protocol developed by Protec's in-house Research and Development team is utilised by the Protec Algo-Tec™ 6300 interactive digital addressable fire control systems. Immunity to false alarms, more responsive fire detection, and ease of use has all been achieved to develop one of the most reliable systems available.

### Protec Algo-Tec™ 6300

The name Algo-Tec™ is a derivative of Protec algorithms. Algorithms are logical mathematical procedures for solving problems. Protec have developed fire detection algorithms coupled with fuzzy logic specifically designed to reduce unwanted fire alarms and to enhance the sensitivity of the system to true fire phenomenon. The Algo-Tec™ algorithms are exclusively utilised by the Protec Algo-Tec™ 6400 and 6300 Interactive Digital Addressable Fire Control Systems.

### Interactive

Algo-Tec™ evaluates the data of each fire sensor and is able to learn from the information received. This may simply be to recognise that a sensor is becoming contaminated or in a dirty environment and to automatically increase the alarm threshold to compensate for the background levels (Threshold Compensation).

More complex Algo-Tec™ functions include the ability to discriminate between certain fire and non-fire conditions, filtering out certain environmental stimuli, and increasing the sensitivity of a sensor when an increase in temperature is detected.

The net effect of the interaction between the sensors and the Algo-Tec™ decision making is enhanced performance, through immunity to false alarms and more responsive fire detection.

### Digital Addressable

The data communication between the sensors and the control equipment is Digital.

The Algo-Tec™ protocol utilised by the 6000 system enables high levels of data to be transferred, providing far more detailed information than was previously achievable with analogue addressable systems. It should however be noted that many analogue addressable systems use digital communication but do not transfer the high levels of data associated with the Algo-Tec™ protocol. Speed, stability, excellent EMC and security all serve to enhance the Algo-Tec™ Digital signalling. Why go analogue addressable when you can now choose Algo-Tec™ Digital Addressable.



### Algo-Tec™ 6000PLUS Interactive Decision Making Algorithms - Typical Applications

#### Office Mode (High Performance)

**DISCRIMINATING ALGORITHM**  
Cigarette Smoke

ALARM Computer Fire

ALARM Bin Fire

#### Clean Mode (Extra High Performance)

ALARM Computer Room Fire

ALARM Printer Paper Fire

ALARM Chemical Fire

#### Day/Night Mode

Offices Factory Loading Bay

Day Mode: Office mode (high performance) Day Mode: Heat detection only (6000PLUS/OPHT)

Night Mode: Clean mode (Extra high performance) Night Mode: Smoke & Heat detection

#### Bedroom Mode

**DISCRIMINATING ALGORITHM**  
Steam From Bathroom

**DISCRIMINATING ALGORITHM**  
Aerosols in Bedroom

ALARM Smoldering Fire

NOTE: The above examples give an indication of system reaction to intermittent contaminants and typical fire sources in a correctly designed BS5839 system. They by no means detail the full complexity of the systems decision making algorithms. Examples are for 6000PLUS/OPHT.

## Typical 6300 Network System

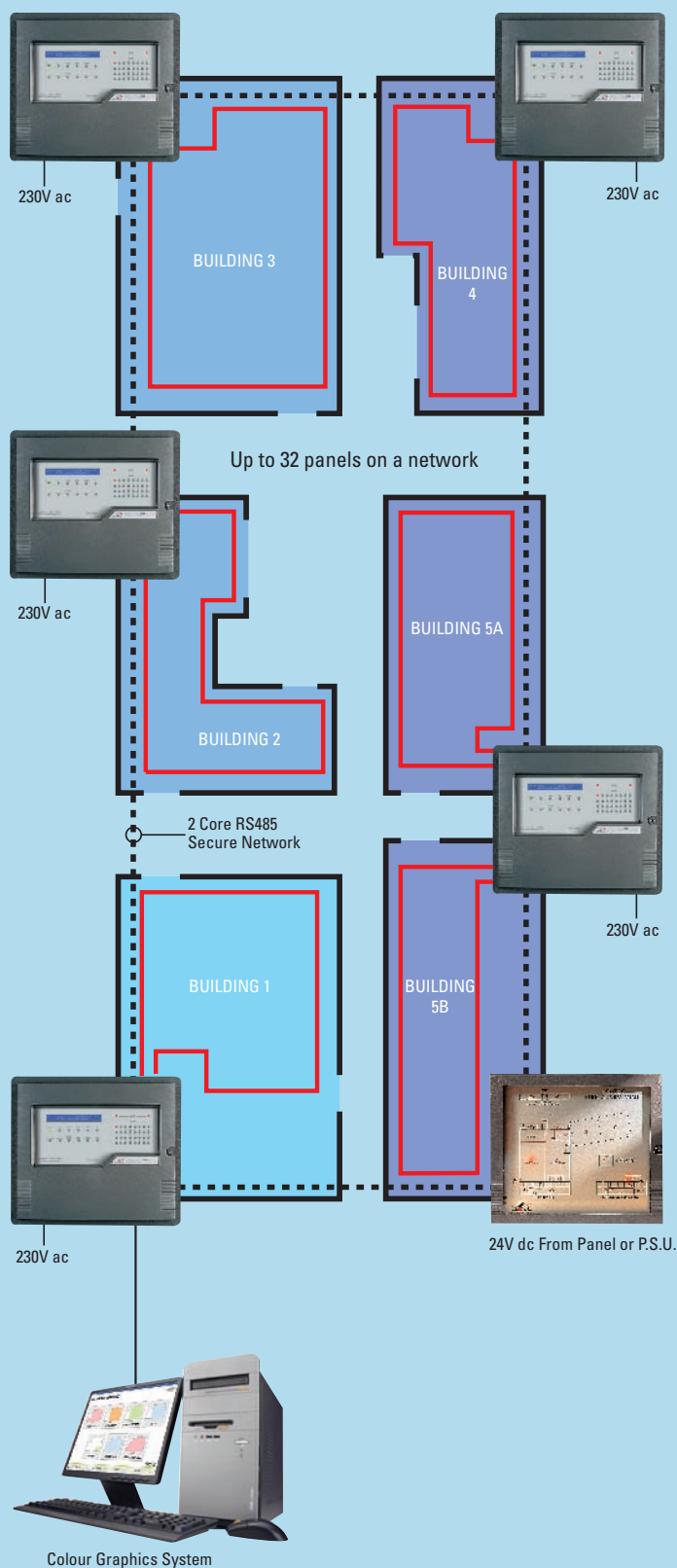

### FEATURES & BENEFITS

- **Cost Effective -**

High specification interactive digital addressable fire detection and alarm system, providing a cost effective solution for small, medium and large sized buildings and sites.

- **Design Flexibility -**

Up to 32 control panels, repeats and illuminated zonal mimics can be networked enabling system design and expansion to be easily achieved to suit the site for economic wiring and operational convenience.

- **Secure Network -**

Wired as a loop, the network's dual channel RS485 link ensures that no single fault will affect the system.

- **Easy to Install -**

An extensive range comprising Loop Powered Alarm Sounders, Beacons, Interfaces, Manual Call Points and Sensors can all be connected to the nearest control panel using a single 2-core cable for each of the high capacity Loops (up to 4), accommodating up to 191 devices per Loop, 512 maximum per panel.

- **Reduced False Alarms -**

The Protec Algo-Tec™ 6000 interactive fire sensors utilise advanced discriminating algorithms for maximum reliability and immunity to false alarms.

- **Enhanced Performance -**

The Protec Algo-Tec™ 6000 sensors learn from their environment, applying interactive decision making algorithms to provide stability, threshold compensation and optimised performance.

- **Secure Detection Loops -**

Many Protec Algo-Tec™ 6000 devices incorporate built-in short circuit isolator units. These can be located as required.

- **Easy to Address -**

'FAST' addressing (Firmware Addressed Secure Technology) ELIMINATES troublesome and time consuming setting of address cards and DIL switches.

- **Devices Display Address Number -**

'RVAV' Remote Visual Address Verification. Confirmation of the correct location of each device can be easily identified, using the devices in-built LED to indicate the device address number.

- **On Site Flexibility -**

Configuration of all system functions is fully site programmable.

- **Reduced Maintenance Costs -**

Early indication and reporting of sensors approaching contamination level reduce false alarms and enable dirty sensors to be cleaned or replaced.

- **Optional RS232 Port -**

Typically used to connect to a colour graphics system, pager system or BMS interface. Allows PC connection for backup and programming.

- **Designed to EN 54-2 & 4**

# Protec

Protec Fire Detection plc

Protec Algo-Tec™ 6300

INTERACTIVE DIGITAL ADDRESSABLE

FIRE CONTROL SYSTEM

## CONTROLS & DISPLAYS

### System Features

The Protec Algo-Tec™ 6300 is an interactive digital addressable fire detection and alarm system ideally suited for small, medium & large sized buildings such as nursing homes, hotels and offices. The control panel is designed and manufactured by Protec to comply with EN 54-2 & 4. The control panel is available as surface or recessed mounted with a moulded polycarbonate hinged door finished in storm grey, or optionally with polished solid brass or brushed stainless steel finish for recess mounting only.

### Secure Network

Up to 32 Algo-Tec™ 6300 control and repeat panels and illuminated zonal mimics can be interconnected using the optional add in 6300 network card. Wired as a loop the networks dual channel fault tolerant RS485 ensures that no single fault can disable the system. In the event of multiple faults, each panel will function independently. The network can be wired using copper or fibre optic cables.

### Non Networked Stand Alone System

For small single panel systems, the serial communication link can be utilised to signal, up to 4 repeat panels using a 4 core screened cable. A network card is not required.

### Loops

Each 6300 control panel is equipped with 1, 2 or 4 high capacity Algo-Tec™ digital addressable data loops, with up to 191 address capacity per loop. Total panel devices is restricted to 512 inputs to comply with EN54 part 2. In addition to sensors, interfaces and manual call points the loop can also support loop powered SOUNDERS, BEACONS and OPTICAL BEAM DETECTORS. Loop powered sounder bases adopt the sensor address to increase the capacity of the loops still further, resulting in reduced cabling requirements, simplified installation and associated cost savings.

### Alarms

In addition to loop powered sounders and beacons, 4 programmable fully monitored alarm outputs are provided at the panel for alternative wiring arrangements.

### Auxiliary Contacts

One set of double pole changeover contacts, which are programmable.



6300 Loop LCD Display



Zoned Mimic Panel

### 6300 Loop Powered LCD Repeat Display

The 6300/LOOP/LCD can be connected directly to the local Algo-Tec™ digital addressable data loop and takes up just one address. The fascia displays power, fire, fault, disablement and more alarms.

Fire and fault events are displayed on the 2x40 character LCD display and automatically scroll. A backlight ensures that the events can be read in all lighting situations. Fire events have highest priority and inhibit the display of fault events. A new event initiates the internal buzzer and a mute button allows the internal buzzer to be muted.

Loop standby/Alarm load 60mA.

### 6300 Illuminated Zonal Mimic

The Protec 6300 customised, illuminated zonal mimic can be connected to the 6300 control panel in the same way as the 6300 repeat panel. The illuminated mimic is housed in a matching enclosure to the control and repeat panels. The fascia is manufactured from Kemco finished in anodised aluminium effect and can be engraved to our clients scaled drawing typically detailing the building outline and zonal areas and has a viewing area of 360(W)mm x 340(H)mm. Up to 32 LED's can be placed on the fascia and will be illuminated by the appropriate zone activation. The illuminated mimic is available as surface or recessed mounted with a hinged door finished in storm grey, or optionally with a polished solid brass or brushed stainless steel finish recess mounting enclosure and an engraved Kemco fascia in anodised aluminium or brushed brass effect finish.



### Controls and Display

All the functions of the Control Panel are accessed via a modern styled hinged lockable door, moulded from polycarbonate with a clear display viewing window. When opened the door reveals the panel controls and easy to follow operating instructions. These controls are SILENCE, SOUND ALARMS, RESET and ACCEPT plus a MENU push button to enable access to the user menu facilities. The control panel display consists of an 80 large character liquid crystal display, twin common fire LED indicators, 32 separate zonal fire LED's, power on, pre-alarm, system fault, common fault, test and disablement LED's. An optional integral low noise thermal printer is also available.

### Liquid Crystal Display

The 80, large character liquid crystal display will under normal quiescent conditions display the current date and time with the option to also display a 40-character user's message such as site name.

In an alarm or fault condition the LCD will display the device loop, address and zone number and up to 40 characters of user definable location text, programmable on site using Protec 6300/WINTEXT windows based software.

### Device Location Text

Windows based text software is supplied free of charge to our clients to enable you to enter the location text on to the disk supplied and hand to our commissioning engineer for loading into the panel during commissioning. This simple process allows you more flexibility enabling you to make any last minute changes & speed up the entire process.

### Printer

The integral printer is a 40-character low noise thermal printer. In operation the printer will provide on demand real time data of fire and fault conditions including time and date of events along with the device number and location text. By accessing the appropriate function from the user menu facility a variety of reports can be printed including the previous 100 incidents from the event log, the system devices configuration and programming matrix, devices which are becoming due for cleaning and the current status of all devices.

### Power Supply

The 6301, 6302 and 6304 control panels can be supplied with an integral 3A dc switch mode charger and a 24V 10Ah sealed lead acid battery. The system is also available, suitable for use with Protec 9000/BC range remote power supplies with an extensive range of battery and charger sizes.

### On Site Programming

The Protec Algo-Tec™ 6300 system is on site programmable. All of the commissioning configuration data can be entered and/or backed up using the Protec 6300/WINPROG windows based programming software via a PC. This feature enables the system to be re-configured and checked prior to attending site simplifying commissioning works on site, enabling text amendments to be carried out whilst on site and providing an invaluable remote backup should the need arise. The system configuration data can also be printed using the control panels optional in-built thermal printer.



Repeat Panel

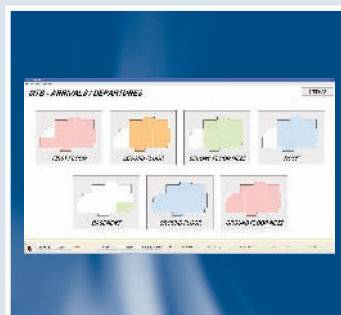

6300 Hercules Colour Graphics System

### 6300 Repeat Panel

The Protec 6300 repeat panel can be connected to the 6300 control panel's serial communications link connection, using a 4-core screened cable.

If the 6300 secure network is utilised then the repeat panel should be connected to the secure network by adding the integral 6300 network card. The repeat panel has an identical display to the control panel including 80 character LCD and 32 zone fire LED's. Full control of silence, accept, sound alarms and reset is included and can be disabled. The repeat panel is available as surface or recessed mounted with a moulded polycarbonate hinged door finished in storm grey, or optionally with polished solid brass or brushed stainless steel finish for recess mounting only.

### 6300 Hercules Colour Graphics System

The Protec Colour Graphics System is a Windows based PC package providing a graphical representation of large sites enabling the precise location of an incident to be readily identified enabling a prompt response. Using touch screen or mouse, the operator can track an incident and zoom from a site plan to intermediate plan listing floor levels, then zoom to a specific floor plan and if necessary then zoom to a specific detailed area within the floor plan showing the device in question. Colour prints of the maps can be printed automatically or on demand.

# Protec

## Protec Fire Detection plc

### Protec Algo-Tec™ 6300

#### INTERACTIVE DIGITAL ADDRESSABLE

#### FIRE CONTROL SYSTEM

#### Loop Devices

The Protec Algo-Tec™ 6000PLUS protocol utilises FAST™ addressing (Firmware Addressed Secure Technology). Every FAST™ device is manufactured with a unique serial number.

FAST™ addressing ELIMINATES troublesome and time consuming address cards and DIL switching whilst being far more secure than "soft addressing".

The Protec Algo-Tec™ 6000PLUS sensor range has been developed to incorporate advanced fire sensing technology, electronic sounders, high intensity LED warning beacons and speech enhanced talking sounder capability, all integrated within the sensor head and powered from the loop.

#### Typical Sensor Variants

- 6000PLUS/OPHT/S = c/w Sounder
- 6000PLUS/OPHT/L = c/w LED Beacon
- 6000PLUS/OPHT/SL = c/w Sounder and LED Beacon
- 6000PLUS/OPHT/TS = c/w Talking Sounder
- 6000PLUS/OPHT/TSL = c/w Talking Sounder and LED Beacon

#### 6000PLUS/HT



**FAST™ Interactive Heat Sensor** - Interactive addressable heat sensor with low thermal mass thermister, giving fast response to temperature increases. Other Heat Sensor variants include: 6000PLUS/HT/S, 6000PLUS/HT/SL, 6000PLUS/HT/TSL

#### 6000PLUS/OP



**FAST™ Interactive Optical Smoke Sensor** - Interactive addressable high performance optical smoke sensor provide efficient reliable detection using the light scatter sensing principle with rapid response to a fire signal. Other Optical Sensor variants include: 6000PLUS/OP/S

#### 6000PLUS/OPHT



**FAST™ Interactive Optical Heat Sensor** - Interactive addressable high performance optical smoke and heat multi-sensor. Other Optical Heat Sensor variants include: 6000PLUS/OPHT/S, 6000PLUS/OPHT/L, 6000PLUS/OPHT/SL, 6000PLUS/OPHT/TS, 6000PLUS/OPHT/TSL

#### 6000PLUS/OPHTCO



**FAST™ Interactive Optical Heat CO Sensor** - Interactive addressable high performance optical smoke heat and carbon monoxide multi-sensor. Other Optical Heat Sensor variants include: 6000PLUS/OPHTCO/S, 6000PLUS/OPHTCO/L, 6000PLUS/OPHTCO/SL, 6000PLUS/OPHTCO/TSL

#### 6000PLUS/BASE



**Low Profile Common Mounting Base** - Compatible with the above range of Algo-Tec™ 6000PLUS Sensors.

#### 6000PLUS/FFBASE



**Fast Fixed Base** - Fast fixed recessed base is designed to recess the sensor into a false ceiling to give a lower profile view of the sensor.

#### 6300/LOOP/LCD Repeater



- Connected directly to the local data loop and takes up just one address. The 1 x 40 character LCD Display provides clear text location of fire and fault events.

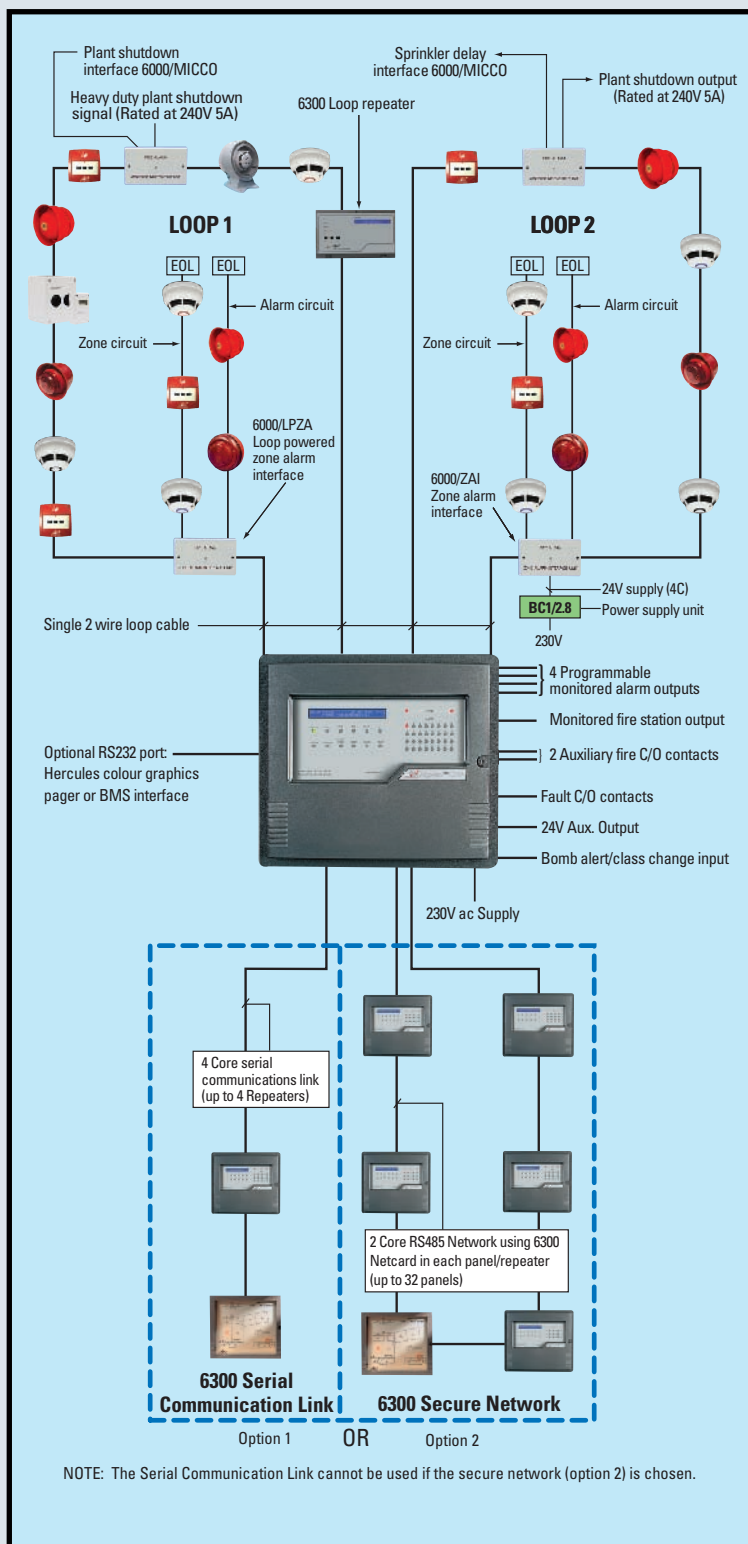

NOTE: The Serial Communication Link cannot be used if the secure network (option 2) is chosen.

#### KEY:

- |  |                                   |  |                                     |
|--|-----------------------------------|--|-------------------------------------|
|  | Heat Sensor                       |  | Zone Alarm Interface                |
|  | Optical Smoke and Heat Sensor     |  | Monitored Input CC Output Interface |
|  | Optical Smoke, Heat and CO Sensor |  | Electronic Sounder                  |
|  | Duct Probe Unit c/w Smoke Sensor  |  | Flashing Beacon                     |
|  | Manual Call Point                 |  | Talking Sounder with LED Beacon     |
|  | Beam Detector                     |  | 6300 Loop LCD Display               |
|  | Loop Powered Zone Alarm Interface |  | 6300 Zonel Mimic                    |
|  |                                   |  | 6300 Repeat Panel                   |

Guide to loop cable conductor sizing for the Protec 6300 system.

		Loop Length (Metres)										
		500	550	600	650	700	750	800	850	900	950	1000
Total Loop Load in Alarm (mA)	50	1.0	1.0	1.0	1.0	1.0	1.0	1.0	1.0	1.0	1.0	1.0
	100	1.0	1.0	1.0	1.0	1.0	1.0	1.0	1.0	1.0	1.0	1.0
	150	1.0	1.0	1.0	1.0	1.0	1.0	1.0	1.0	1.0	1.0	1.0
	200	1.0	1.0	1.0	1.0	1.0	1.0	1.0	1.0	1.0	1.0	1.0
	250	1.0	1.0	1.0	1.0	1.0	1.0	1.0	1.0	1.0	1.0	1.0
	300	1.0	1.0	1.0	1.0	1.0	1.0	1.0	1.0	1.0	1.0	1.0
	350	1.0	1.0	1.0	1.0	1.0	1.0	1.0	1.0	1.0	1.0	1.0
	400	1.0	1.0	1.0	1.0	1.0	1.0	1.0	1.0	1.0	1.0	1.0
	450	1.0	1.0	1.0	1.0	1.0	1.0	1.0	1.0	1.0	1.0	1.0
	500	1.0	1.0	1.0	1.0	1.0	1.0	1.0	1.0	1.0	1.0	1.0
550	1.0	1.0	1.0	1.0	1.0	1.0	1.0	1.0	1.0	1.0	1.0	
600	1.0	1.0	1.0	1.0	1.0	1.0	1.0	1.0	1.0	1.0	1.0	

		Loop Length (Metres)										
		1000	1050	1100	1150	1200	1250	1300	1350	1400	1450	1500
Total Loop Load in Alarm (mA)	50	1.0	1.0	1.0	1.0	1.0	1.0	1.0	1.0	1.0	1.0	1.0
	100	1.0	1.0	1.0	1.0	1.0	1.0	1.0	1.0	1.0	1.0	1.0
	150	1.0	1.0	1.0	1.0	1.0	1.0	1.0	1.0	1.0	1.0	1.0
	200	1.0	1.0	1.0	1.0	1.0	1.0	1.0	1.0	1.0	1.0	1.0
	250	1.0	1.0	1.0	1.0	1.0	1.0	1.0	1.0	1.0	1.0	1.0
	300	1.0	1.0	1.0	1.0	1.0	1.0	1.0	1.0	1.0	1.0	1.0
	350	1.0	1.0	1.0	1.0	1.0	1.0	1.0	1.0	1.0	1.0	1.0
	400	1.0	1.0	1.0	1.0	1.0	1.0	1.0	1.0	1.0	1.0	1.0
	450	1.0	1.0	1.0	1.0	1.0	1.0	1.0	1.0	1.0	1.0	1.0
	500	1.0	1.0	1.0	1.0	1.0	1.0	1.0	1.0	1.0	1.0	n/a
550	1.0	1.0	1.0	1.0	1.0	1.0	1.0	1.0	1.0	1.0	n/a	
600	1.0	1.0	1.0	1.0	1.0	1.0	1.0	1.0	n/a	n/a	n/a	

The conductor size required as follows

- 1.0mm<sup>2</sup> Conductor required
- 1.5mm<sup>2</sup> Conductor required
- 2.5mm<sup>2</sup> Conductor required

MAXIMUM LOOP RESISTANCE 16 OHMS PER CONDUCTOR

Table detailing the loop standby and alarm load for typical Algo-tec™ 6000 devices.

Product	Description	Number of Addresses	Loop Standby Load mA	Loop Alarm Load mA
6000/MCP	Manual Call Point	1	0.5	3.4
6000/FIREBEAM	Loop Beam	1	3.65	7
6000PLUS/HT	Heat Sensor	1	0.2	0.2
6000PLUS/HT/S	Heat Sensor c/w Sounder	1	0.4	5.4
6000PLUS/OPHT	Optical Smoke and Heat Sensor	1	0.2	0.2
6000PLUS/OPHT/S	Optical Smoke and Heat Sensor c/w Sounder	1	0.4	5.4
6000PLUS/OPHT/SL	Optical Smoke and Heat Sensor c/w Sounder and Beacon	1	0.4	10.4
6000PLUS/OPHT/TSL	Optical Smoke and Heat Sensor c/w Talking Sounder and Beacon	1	0.4	13.4
6000PLUS/OPHTCO	Optical Smoke, Heat, and CO Sensor	1	0.45	0.45
6000PLUS/OPHTCO/S	Optical Smoke, Heat, and CO Sensor c/w Sounder	1	0.45	5.45
6000/LED	Loop Beacon	1	0.5	5.5
6000/SSR	Loop Sounder	1	0.7	5.7
6000/SSR/LED	Loop Sounder Beacon	1	0.7	10.7
6000/ZAI*	Zone Alarm Interface	1	2	4
6000/MICCO	Monitored Input CC Output	1	0.55	5

Note: The following Loop Parameters should be observed

- 1) The total number of addressable devices should not exceed 191 per loop.
- 2) Add 20mA to total loop alarm load to allow for fire indicator LED's on devices
- 3) The total loop alarm load should not exceed 600mA per loop.

\* Auxiliary 24V dc supply required.

6000/MCP



**FAST™ Addressable Manual Call Point** - Key operated test facility, a loop short circuit isolator is incorporated.

6000PLUS/UG4DP



**Ventilation Duct Smoke Sensor Assembly** - Single pipe air sampling unit for air speeds from 0.5 to 20m per sec. supplied with 6000PLUS/BASE suitable for use with 6000PLUS/OP FAST™ interactive optical smoke sensor.

6000/FIREBEAM



**FAST™ Addressable Loop Powered Beam Detector** - Combined transmitter/receiver unit and separate low level controller. With a beam range of 5-100 metres.

6000/LED



**FAST™ Addressable Loop Powered High Intensity Flashing Beacon** - The 6000/LED has 18 high intensity LEDs, and due to the low current design, is addressable and loop powered, utilising the Protec Algo-Tec™ 6000 Protocol.

6000/SSR



**FAST™ Addressable Loop Powered High Output Electronic Sounder** - utilises a Piezo driver unit to enable high sound output and very low current consumption.

6000/SSR/LED



**FAST™ Addressable Loop Powered High Output Electronic Sounder with LED Beacon** - a low current loop powered addressable device. With typical sound output of 100dB(A) at 1m, the tone and volume options are selectable by the control panel.

6000PLUS/TSR2



**FAST™ Addressable Loop Powered Talking Sounder** - The 6000PLUS/TSR2 voice enhanced talking sounder is available with seven voice messages plus 'bell' sound in addition to the three fire alarm tones compatible with the Protec range of electronic sounders.

6000PLUS/TSR2/LED FAST™ Addressable Loop Powered Talking Sounder with LED Beacon



- the Protec Algo-Tec™ 6000PLUS/TSR2/LED is equipped with an integrated voice enhanced sounder and high intensity flashing beacon array.

6000/FIU



**Flush Mounted Short Circuit Isolator Unit** - To isolate a short circuit fault on either the incoming or outgoing loop cables. Suitable for a 30mm deep electrical mounting box.

6000/LPZA



**FAST™ Addressable Flush Mounted Loop Powered Zone Alarm Interface Unit** - With a monitored detection circuit suitable for use with Protec 3000 series detection devices. Line continuity maintained. Monitored alarm output circuit rated at 24Vdc 50mA max. Suitable for a 45mm deep electrical mounting box. A loop short circuit isolator is included.

6000/ZAI



**FAST™ Addressable Flush Mounted Zone Alarm Interface Unit** - With a monitored detection circuit suitable for use with Protec 3000 series detection devices. Line continuity maintained. Monitored alarm output circuit rated at 24V dc 1A max. Suitable for a 45mm deep electrical mounting box. A loop short circuit isolator is included.

6000/MICCO



**FAST™ Addressable Flush Mounted Loop Powered Monitored Input, Clean Contact Output Interface Unit** - With a monitored input circuit suitable for use with simple switch devices and the output is a clean changeover contact 5amp rated at 240V ac. A link can be cut to provide a 7-second delay to the input. Suitable for a 45mm deep electrical mounting box. A loop short circuit isolator is incorporated.

Multi-way Input/Output Interfaces - A range of 16 way input/output



interfaces are available with monitored alarm outputs or clean changeover contacts. All interfaces are FAST™ addressable.

## Technical Specification 6300 Control Panel

### Models:-

Complies with EN54-2 & 4

**6301** - Single Loop Panel  
**6302** - 2 Loop Panel  
**6304** - 4 Loop Panel

### Specification:-

Power Supply  
Working Voltage  
Temperature Range  
Maximum Humidity  
Panel Model  
Standby Load (Mains Fail Condition)  
Alarm Load (Mains Fail Condition)

Mains 230V ac nominal  $\pm$  10%.  
21.5 - 30V dc.  
0 - 40°C.

85% Non-condensing.  
**6301**      **6302**      **6304**  
90mA      115mA      170mA  
210mA      260mA      345mA



LPCB ref. no. 201ad

Display  
Digital Addressable Loops

Backlit liquid crystal display 2 lines of 40 characters.  
1,2 or 4 loops, each with 191 address capacity. Total panel capacity is restricted to 512 Input addresses to comply with EN 54-2. Algo-Tec™ 6000 Protocol.

Total Loop Load  
Zones  
Integral Charger  
Integral Battery  
Remote Power Supply

600mA per loop including all loop connected devices.  
32 Zone LED's plus twin red common fire indicators.  
3A dc Switch-mode.  
10Ah 24V sealed lead acid.

Programmable Alarm Outputs

The Protec 9000/BC range of power supplies are compatible with the 6300 panels.  
Dual path outputs and fault signalling, (4 wire plus 2 wire, 2 primary power, 2 signals, 2 secondary power).  
4 Monitored - Internal sounder circuits (1A rated @ 24V).

Alarm Load  
Fault Monitoring  
Fault Output  
Serial Communications Interface  
Secure Network

1 Set of non-monitored double-pole changeover contacts (1A rated @ 24V).  
Up to 191 alarm outputs per loop with the use of additional loop O/P devices.  
Maximum 3A with integral power supply unit.

Auxiliary Output Supply  
Common Fire Output (fire station)  
Common Fault Output (fire station)  
RS232 Communications Interface  
Optional Integral Printer  
Dimensions (mm)  
Approvals

Fully fault monitored to EN 54-2.  
Single pole changeover contacts (1A rated @ 24V).  
4 wire (2 power, 2 data) for up to 4 repeat/mimic panels.  
To replace above serial interface when optional 6300 network card fitted to allow up to 32 panels / repeaters to be securely networked (2 wire loop).  
24V dc fused at 250mA.  
24V dc fully monitored output rated at 20mA. 1K EOL.  
24V dc fully monitored output rated at 20mA. 1K EOL.  
9 way 'D' type connector (Male). For program/text software upload/download.  
40 character low noise thermal printer.  
440(W) x 385(H) x 144(D).  
(6301) LPCB Certificate No: 201ad/07, EC Certificate No: 0832-CPD-1474, Relevant Standard: EN 54-2 & 4.  
(6302) LPCB Certificate No: 201ad/08, EC Certificate No: 0832-CPD-1475, Relevant Standard: EN 54-2 & 4.  
(6304) LPCB Certificate No: 201ad/09, EC Certificate No: 0832-CPD-1476, Relevant Standard: EN 54-2 & 4.

### Programmability

96 Input Groups System Wide  
96 Output Groups per Panel  
  
32 Zonal Output Groups per Panel

First 32 have an independent programmable time-out delay.  
First 32 have an independent programmable delay for first 32 input groups.  
Each is programmable as an alarm or control output.  
Each is activated by a separate zone input for zones 1 to 32.  
Programmable master time-out.  
Selectable Coincidence Detection.  
24 programmable Non-latching addresses.  
24 programmable Non-latching Fire addresses.

### 6300 Repeat Panel/ 6300 Illuminated Zonal Mimic

Power Supply  
Standby Load  
Alarm Load  
Serial Communications Link  
Secure Network

24V dc from local power supply or internal charger and battery (230V ac required).  
50mA.  
50mA.  
4 wire (2 power, 2 data) for up to 4 repeat/mimic panels.  
To replace above serial interface when optional 6300 network card fitted to allow up to 32 panels/repeats to be securely networked (2 wire loop).  
440(W) x 385(H) x 144(W).

Dimensions (mm)

### 6300 Netcard

Standby/Alarm Load

Optional network card fitted to each control panel and repeat to be networked.  
The network card replaces the serial communication link. Up to 32 panels/repeats can be securely networked (2 wire loop).  
70mA per network card.



<b>Protec: Scotland</b> Tel: 0845 456 5390 Fax: 0845 456 5391	<b>Protec: North East</b> Tel: 0845 456 5396 Fax: 0845 456 5397	<b>Protec: Yorkshire</b> Tel: 0845 456 5388 Fax: 0845 456 5389	<b>Protec: Midlands</b> Tel: 0845 456 5398 Fax: 0845 456 5399	<b>Protec: South East</b> Tel: 0845 456 5394 Fax: 0845 456 5395	<b>Protec: South West</b> Tel: 0845 456 5392 Fax: 0845 456 5393
---	---	--	---	---	---

Company Policy is one of continuous improvement, we reserve the right to change specification without prior notice  
**Protec Fire Detection Plc, Protec House, Churchill Way, Nelson, Lancashire, BB9 6RT**