



## Providers of Reliable Nurse Call Communications

**Protec Fire Detection Plc,  
Protec House,  
Churchill Way,  
Nelson,  
Lancashire,  
BB9 6RT**

Company policy is one of continuous improvement, we reserve the right to change specification without prior notice  
Axio-i-Tec is a registered trademark product of Televic-Belgium

Founded in 1968 Protec is a name synonymous within the UK Building Safety Systems Industry.

Protec now brings you Axio i-Tec nurse call. Manufactured to meet and exceed the UK applicable standards.

Providing a high quality product combined with Protec's track record in delivery of successful project completion for its clients.

**Providing comfort and reassurance for both staff and patients in today's modern hospital.**

# ***SOLUTIONS FOR TODAY'S AND TOMORROW'S HOSPITALS***

Axio i-Tec is more than just another nurse call system, built and designed for today's busy hospitals combining a reliable and robust engineered product with the support network backbone essential in today's high speed world.

Major design objectives are:

- To offer maximum comfort and safety to the patient.
- To reduce non medical staff tasks for the nurses
- Providing efficient management of the nursing personnel
- To provide information to assist the management planning
- To offer greater assistance to facilities management and engineering departments.
- Offering greater flexibility to the changing needs of the hospital
- To offer affordable nursing communication systems

Patients and Nursing Staff both require a reliable and easy to function nurse call system, welcome to the world of Axio i-Tec.

It is essential upon activation of a patient call the nurse call system operates in accordance with the expectations of all involved. A series of addressable text displays or PC displays with associated colour coded identification call lights and output buzzers to provide easy identification to nursing staff allowing them to respond to the correct patient call effectively.

To improve the communication systems for today's hospitals Axio i-Tec has been designed to integrate with items such as dect telephones, pagers etc and also to provide information to medical support teams to improve hospital response times at critical moments in the most efficient way.



The hospital environment is currently in a transitional period due to many changing factors such as, life expectancy, government funding, reduced periods of patient waiting times along with reduced periods of stay in hospital. Therefore considerations of systems solutions must match the changing face of the healthcare market sector.



## Solutions for the Hospital Market

### Evolution in hospitals

- Increased number of admissions due to the ageing population
- The smaller hospitals are being integrated into larger hospital trusts
- Decreasing admissions period, transfer to home care or special units
- The emerging importance of ICT and improved efficiency
- Higher demands for centralised information and reports
- Patients comfort and movement during their hospital stay
- Hygiene concerns and demands

### “NO” to the hospital Bacteria

Improved hygiene thanks to Axio i-Tec, assisting the NHS in reducing harmful infections.

The existence of the hospital bacteria influences indirectly the working procedures in the modern hospital. Axio i-Tec products are assisting in limiting outbreaks of these infections. Patient hand units are of a waterproof design and can be cleaned utilising anti bacterial solvents.

The hand units themselves are fully compliant to a IP68 level and can be submerged for several hours between different patient use, thus reducing possible cross contamination between patients.

## Axio i-Tec Features and Benefits:

**Easy to Install:** Utilising an industry standard Cat5 utp cable and 24v, nurse call has never been easier to install. Providing both bus wired and star wired options.

**Flexible Software:** With Easy Lynx we provide a modular software application for the Axio i-Tec user allowing for upgrades and improved functions to be easily accommodated providing more useful information to the management team than ever before. Easy Nurse, Easy View, Easy Trace, Easy Guard.

**Modular Components:** To reduce system downtime and to minimise disruption to the nursing staff Axio i-Tec has been developed for easy modifications and rectifications by Estates and FM teams at affordable levels.

**Site Network:** Either stand alone or shared network options are available depending upon the client design requirements, to provide up to the minute nurse call systems information to the right personnel when the information is required. Individual systems remain totally unaffected with total protection to the system should networks fall over. Also assisting in potential re-routing of calls.

**Speech Systems:** Protec are pleased to offer a two way speech system for those staff who appreciate the benefits speech can bring by improved productivity in wards by nursing staff. Including Intercom between two points, remote from the nurse base.

**Remote Diagnostic:** In an attempt to reduce wasted journeys and high engineering call out costs and to improve efficiency Protec can provide a remote diagnostics contract to support systems training already provided to the end user service and maintenance personnel.

**Integrated Paging:** Protec are pleased to offer an integrated paging solution to keep the nursing and security staff in touch with system developments aiding improved information sending. An option to encompass existing systems on site may be available.

**Attack Systems:** As part of nurse call delivery we appreciate that staff can be at risk of attack from aggressive patients and members of the public from time to time, recognising this point we are able to offer both fixed and roaming attack systems to suit the client operational requirements on a bespoke basis.

**Baby Tagging:** Providing a suitable solution for today's modern world we are happy to provide you a simple and robust system providing both staff and parents with the safety net required within maternity and special care units.

**FM/Maintenance Training:** Protec are pleased to provide our client's FM and maintenance staff with Axio i-Tec training, allowing them the ability to deal with the majority of engineering problems in house in an attempt to reduce cost and improve client confidence in the product

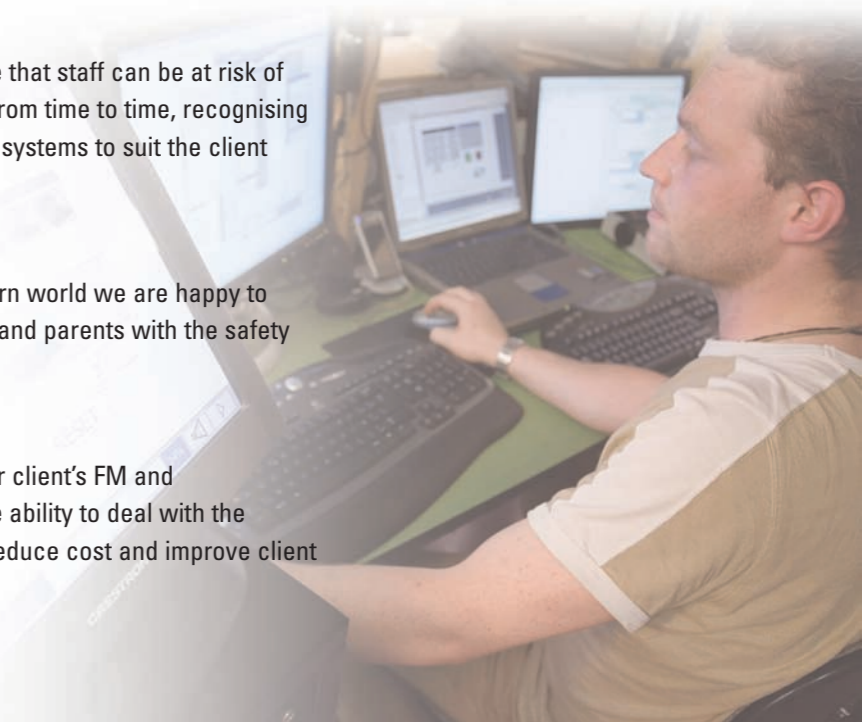
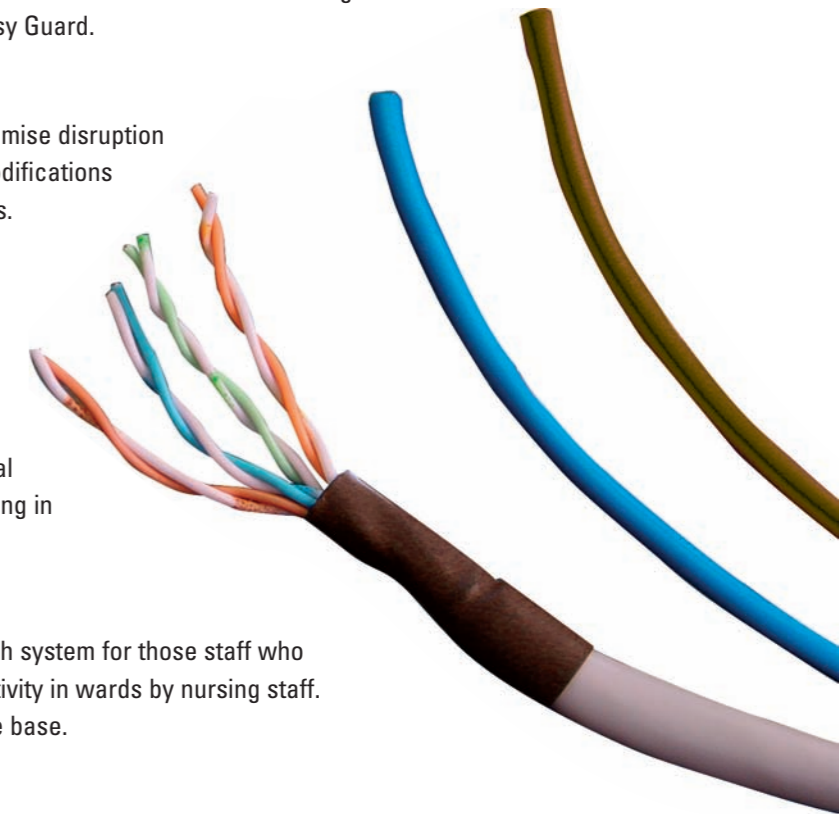

# Project Support and Design Assistance

Since 1968 Protec's reputation has grown as a company who has an excellent track record in delivering successful project completion along with leading products.

Axio i-Tec is no different and we are pleased to provide support to a project team at any stage from project concept right through to handover upon project completion.

Protec is set up to provide the necessary commitment to the Hospital contracting industry to supply a level of design support and product delivery second to none.

Every nursing ward has its specific requirements. Axio i-Tec can be adapted to each and every one of these specific needs, by providing a stable software platform built for all systems supplied and then enhanced with our clients bespoke software to provide the system of operation and bespoke services required.

So whether it is a very simple small nurse call system or a site wide network system Axio i-Tec is the right product for you to consider.

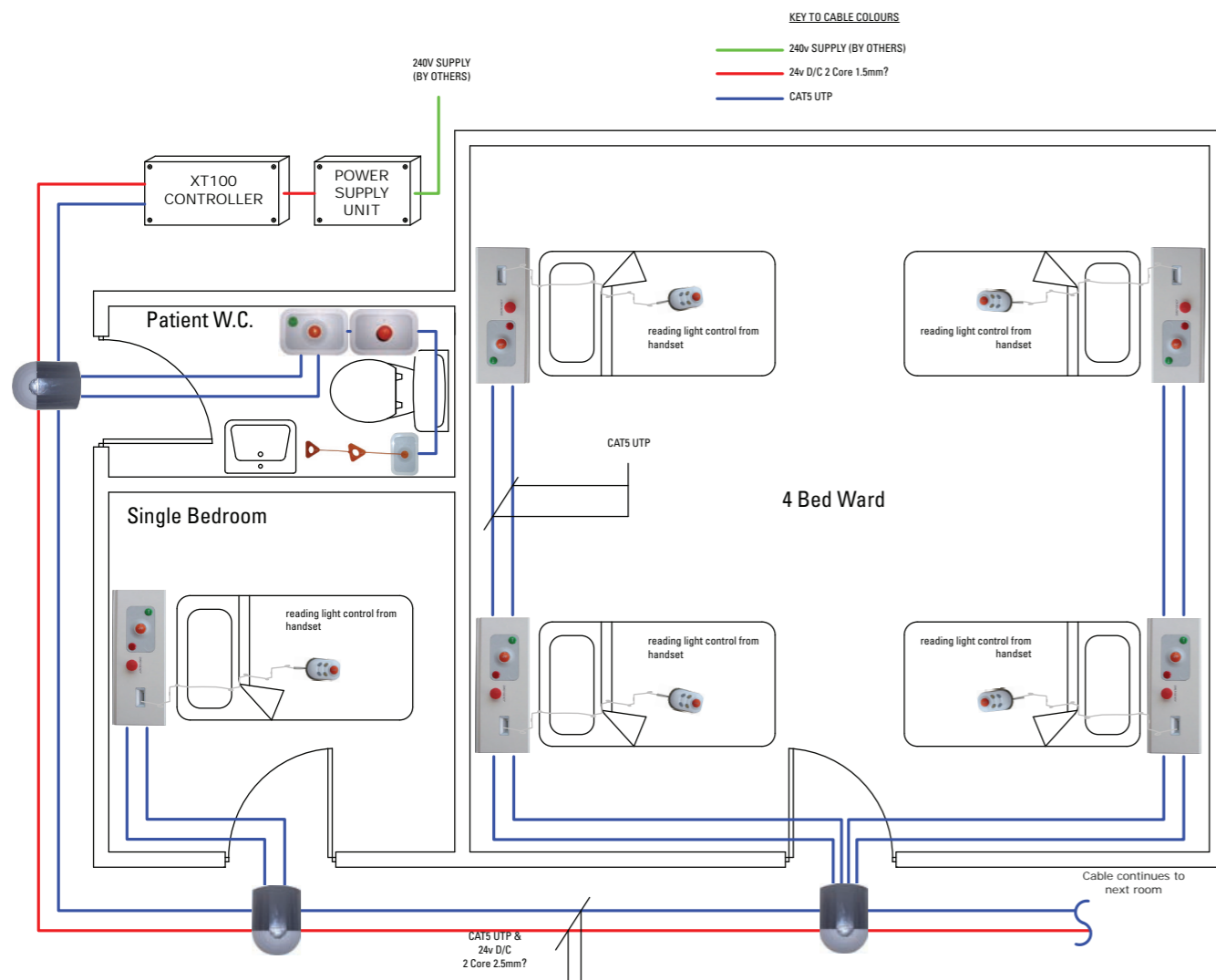

Integrated Paging  
Modular Components  
Speech Systems Flexible Software  
Facilities Management Training  
**Nurse Call Network**  
Remote Diagnostics  
Baby Tagging Easy Install  
Paging Attack Systems

