



INVESTOR IN PEOPLE
MANUFACTURING
ACCOUNTS • R & D

Protec

Protec Fire Detection plc

RIBBLE

LUMINAIRE



Dimensions (mm)

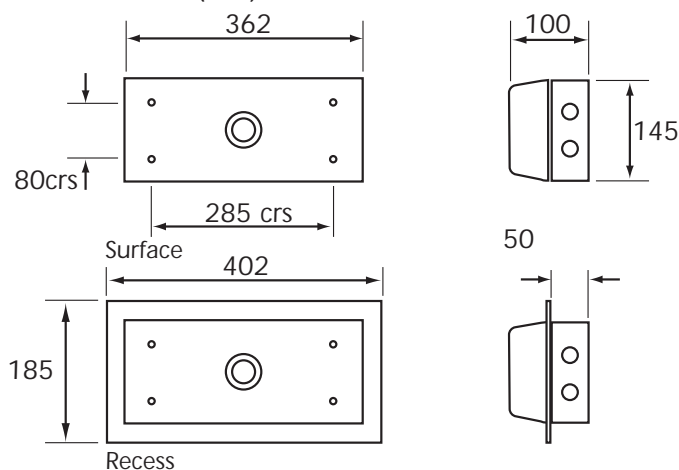

- Surface or recess mountable.
- Cable entry on each end side with BESA in rear.
- Available in maintained, non-maintained, central battery and mains only versions.
- Compatible with Protec AL255 automatic addressable testing system.
- Manufactured to EN 60598:2.22

The Ribble luminaire is designed to be vandal resistant yet retain its aesthetic appearance and is offered in surface and recessed models.

The surface model allows rear, end and side entry, while the recessed model allows rear entry and is complete with an attached bezel in durable white epoxy powder coating. Combined general and emergency luminaires are also available to special order, utilising energy saving PL lamps.

The prismatic diffuser (opal available to special order) is injection moulded from a self-extinguishing polycarbonate material.

Notes:

Prefix ST/ for Self Test Luminaire

Prefix AD/ for addressable E.L. interface for use with AL255 automatic testing system

Opal Diffuser (to special order) replace "/P/" with "/O/".

Euro Legend Self adhesive European directive format exit legend, order ref: SELF/EURO.

Max Viewing Distance 18 metres based on the latest draft European directives

RIBBLE SELF CONTAINED LUMINAIRES					
Stock Code	Sales Order Code	Mode	Emergency Lamp Output	Normal Lamp Output	Source (WATTS)
74-316-68	RL8/P/NM3	NM	180 Lumen	N/A	8W
74-336-72	RL8/P/M3	M	180 Lumen	400 Lumen	8W
74-356-76	RL8/P/S3	S	180 Lumen	400 Lumen	8W(E)8W MAINS

Mode NM = Non Maintained M = Maintained S = Sustained

RIBBLE CENTRAL BATTERY LUMINAIRES					
Stock Code	Sales Order Code	Emergency Lamp Output	Central Battery Power Input		Source (WATTS)
			AC(VA)	DC (WATTS)	
74-406-69	RL/P/8/24	320 Lumen	10.5	7.5	8W
74-426-73	RL/P/8/50	360 Lumen	11.5	8.5	8W
74-446-77	RL/P/8/110	360 Lumen	10	8.5	8W

Suffix /SUS for 8 watt sustained lamp 240V AC.

RIBBLE MAINS ONLY LUMINAIRES					
Stock Code	Sales Order Code	Normal Lamp Output	Input Watts		Source (WATTS)
			Without PFC	With PFC	
74-466-81	RL8/P/240	400 Lumen	38	15	8W
74-472-79	RL11/P/240	850 Lumen	46	21	11(PL)

Input Voltage 220/240v 50HZ. Suffix /PFC for power factor correction to 0.85.

ICEL

BFPSA
British Fire Protection Systems Association



BS EN ISO 9002
Cert. No. FM 10567



INTRUDER ALARMS
Cert. No. 100316



ISO 9001 Certificate
No.s. 201, 188 & 268

Head Office:

Protec House,
Churchill Way, Nelson,
Lancashire BB9 6RT
Tel: (01282) 717171
Fax: (01282) 717273

South East Office:

Crayfield House, Crayfield
Industrial Park, Main Road,
Orpington, Kent BR5 3HP
Tel: (01689) 894700
Fax: (01689) 894701

Leeds Office:

Copley Hill Trading Estate,
Whitehall Road, Leeds
LS12 1HF
Tel: (0113) 220 4400
Fax: (0113) 220 4401

Midlands Office:

Albrighton House, 135
Allport Street, Cannock,
Staffordshire WS11 1JZ
Tel: (01543) 468646
Fax: (01543) 468647

Scotland Office:

The Glass Cube, Wyman
Gordon Complex, Houston
Road, Livingston EH54 5BZ
Tel: (01506) 498167
Fax: (01506) 498168

