

- 6000PLUS/UG4DP for use with Protec Algo-Tec™ 6000 Interactive Digital Addressable Fire Detection Systems
- 3000/UG4DP for use with Protec Non Addressable Fire Detection Systems
- One-Pipe Air Sampling System
- Patented Venturi Pipe and Duct Housing Test Hole on Cover
- Simple Installation
- Sensitive Flow Indicator
- Filter for Dusty Environments
- Foolproof Installation of Venturi Pipe



3000/UG4DP  
6000/UG4DP  
6000PLUS/UG4DP

### Ventilation Duct Smoke Detector Assembly

The duct smoke detector provides early detection of smoke and products of combustion present in air moving through an HVAC duct. The assembly requires a 3000/OP optical smoke detector head, 6000/OP or 6000PLUS/OP digital addressable head.

The unit has been specially constructed to allow optimum airflow through the smoke detector's chamber.

A revolutionary 'one pipe system', the Venturi Principle, is achieved by the use of a single pipe with two built-in channels which directs the airflow smoothly through the detector's chamber and returns the air back into the duct. An airflow indicator confirms airflow through the unit itself when the airflow is above 0.75 m/sec.

The 'one pipe system' and in-built connection block for termination of cables makes the unit far easier to install than its competitors. The duct probe is supplied with full fixing instructions and a mounting template.

The air sampling tube is provided in three standard lengths to suit the HVAC duct.

### Model Numbers

**3000/UG4DP6**  
**6000/UG4DP6**  
**6000PLUS/UG4DP6**

Duct assembly c/w 600mm sampling tube for 150 mm to 800 mm duct diameter

**3000/UG4DP15**  
**6000/UG4DP15**  
**6000PLUS/UG4DP15**

Duct assembly c/w 1500mm sampling tube for 600mm to 1300mm duct diameter

**3000/UG4DP28**  
**6000/UG4DP28**  
**6000PLUS/UG4DP28**

Duct assembly c/w 2800mm sampling tube for 1300mm to 2600mm duct diameter

# Technical Specification

## Dimensions (mm)

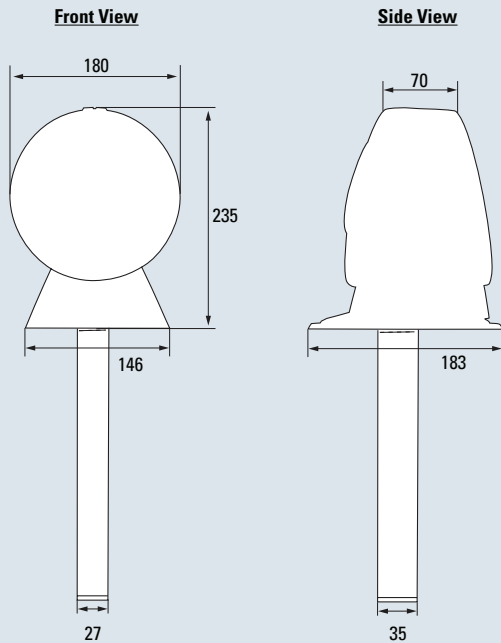

## Technical Specification

<b>Air Velocity</b>	0.5m/s to 20m/s
<b>Sampling Pipe</b>	Aluminium
<b>Operating Temperature</b>	-10°C to +50°C
<b>Humidity</b>	95% non condensing
<b>Weight</b>	0.8Kg (approx)
<b>Detector Heads</b>	3000/OP, 6000/OP or 6000PLUS/OP OP = Optical smoke detector. Note: Detector heads sold separately

## Optional Mounting Bracket



For mounting of duct smoke detector, on circular or insulated flat ducts.  
 Stockcode: UG4DP/MB

## Installation Details

