

24V Power Supply Unit

- Self-Contained Power Supply and Charger
- Approved to EN-54-4 and EN12101-10
- Lockable Enclosure
- Surge Protection Technology
- Short Circuit Protection
- Overload Protection
- Overvoltage Protection
- Tamper Switch Capability
- LED PSU Status Indication



The Pulsar EN54C-10A power supply and charger is a lightweight, high efficiency unit, compliant and third party tested to the latest version of EN 54-4 for use with Protec's range of 24 Volt DC equipment.

The unit provides a 24 V (nominal) output from a 230 V mains input and automatically switches to a standby battery supply should the mains supply fail. Under normal conditions, the standby batteries are intelligently charged and monitored to ensure that, should they be needed, they are in optimal condition.

Technical Specification

Rated voltage (AC)	~230 V
Rated frequency	50Hz
Maximum quiescent load	8.2 A (for continuous operation) [EN54-4 I max. a]
Maximum alarm load	10 A (intermittent operation, only when batteries are fully charged) [EN54-4 I max. b]
Ingress protection	IP30
Ambient temperature limits	-5°C to +40°C
Humidity limit	95% Relative Humidity (no condensation or icing)
Output voltage range (DC)	22.0 V to 27.6 V DC – Buffer Operation 20.0 V to 27.6 V DC – Battery Assisted Operation
Compatible battery types	Yucel 12 V SLA battery (2 in series). For suitable capacity see compatible battery types table below
Battery charging current	1.8 A
Battery monitoring	SCP, OLP, OVP, UVP, Tamper
Fault relay contact	1 A @ 30 V DC / 50 V AC
Cabinet material / finish	Steel plate DC01 1.2mm, Colour: RAL7016 (Grey)

Order codes

Sales code	Supplied batteries (12 V)	Order code(s)
EN54C-10A17	2 X 17Ah	67-800-00 + N 13-135-31YU x 2
EN54C-10A24	2 x 24 Ah	67-800-00 + N 13-140-28YU x 2
EN54C-10A38	2 x 38 Ah	67-800-00 + N 13-150-30YU x 2

Compatible battery types

Capacity	Order code
17 Ah	N 13-135-31YU
24 Ah	N 13-140-28YU
38 Ah	N 13-150-30YU

Dimensions (mm)

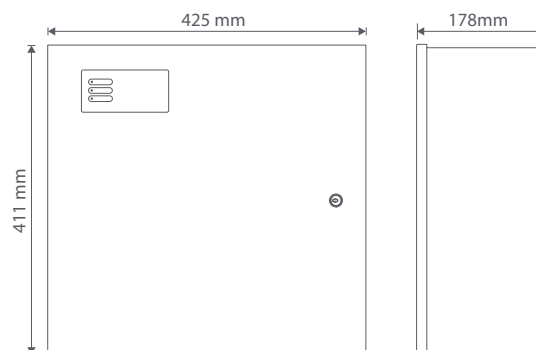

Technical data, courtesy of Pulsar

Company Policy is one of continuous improvement, we reserve the right to change specification without prior notice

Protec House, Churchill Way, Nelson, Lancashire, BB9 6RT

© 2023 Protec Fire and Security Group Ltd

Tel: +44 (0)1282 717171 Web: www.protec.co.uk Email: sales@protec.co.uk